

SIEMENS



SINAMICS V90

The performance-optimized and easy-to-use servo drive system

siemens.com/sinamics-v90



 :051-37133855-6

 :09014284236

WWW.ARCOKALA.COM

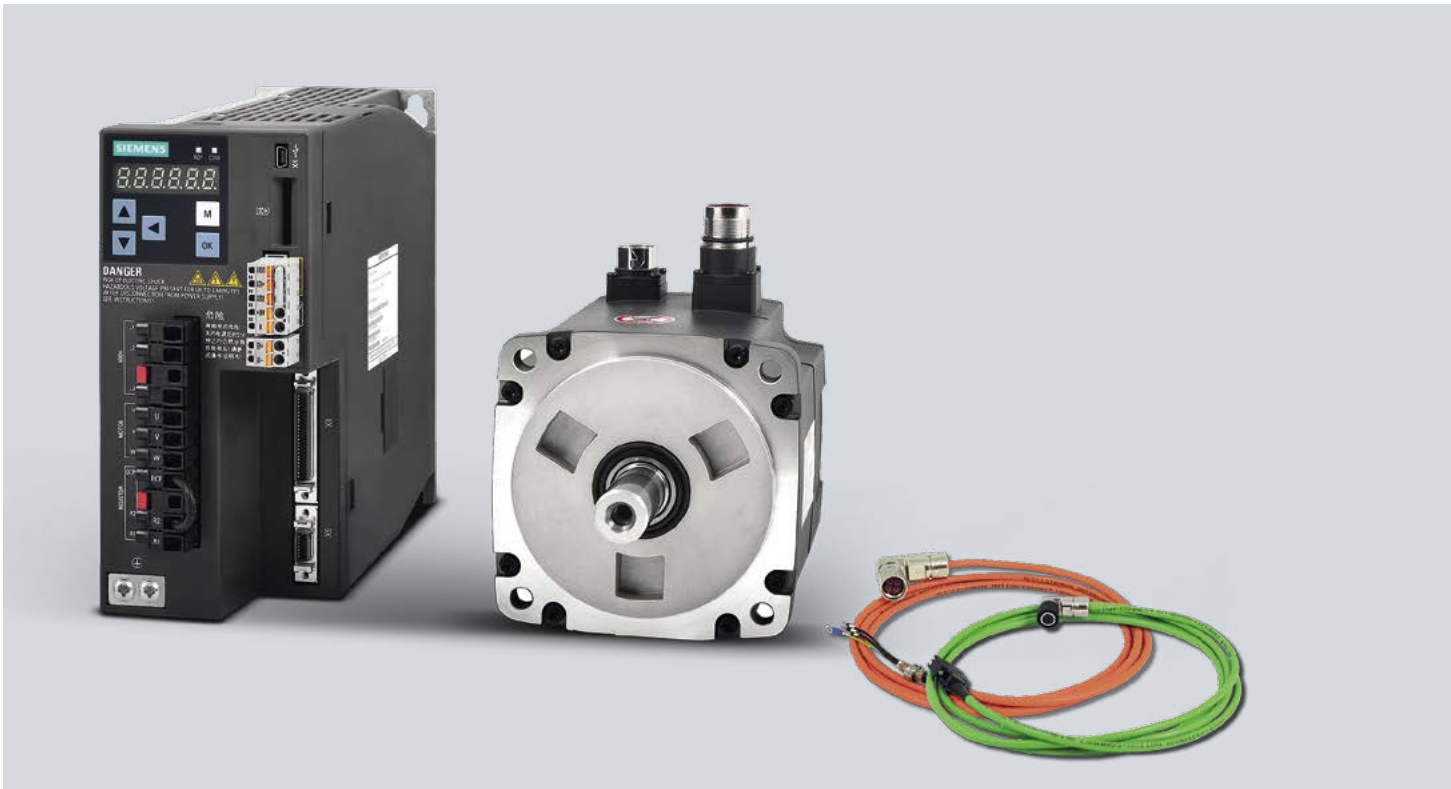

Content

System overview	03
System highlights	06
SINAMICS V-ASSISTANT engineering tool	10
Complete solution for motion control applications	11
SINAMICS V90 technical data and control features	12
SINAMICS V90 dimensions and mounting clearances	15
SIMOTICS S-1FL6 technical data and torque-speed characteristics	16
SIMOTICS S-1FL6 dimension drawings	18
System overview and connection diagrams	20
SINAMICS V90 and SIMOTICS S-1FL6 ordering information	22

SINAMICS V90 and SIMOTICS S-1FL6

Belonging to two comprehensive drive technology families

SINAMICS V90 is the new member of the SINAMICS drive family, and SIMOTICS S-1FL6 is the new member of the SIMOTICS motor family. Together, they form an optimized servo drive system for positioning, as well as speed and torque control. Through its optimized design, the system ensures high servo performance in a cost-efficient and easy way as well as a high degree of ruggedness.

SINAMICS and SIMOTICS products are part of Siemens Integrated Drive Systems. Drive technology based on Integrated Drive Systems ensures maximum productivity, energy-efficiency, and reliability in any automation environment and throughout the entire lifecycle.

The SINAMICS family offers the optimum drive for every application. All drives can be engineered, parameterized, commissioned and operated in the same way.

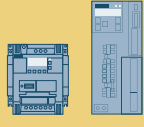
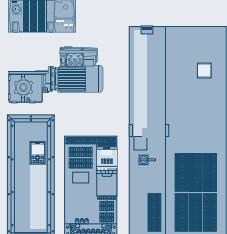
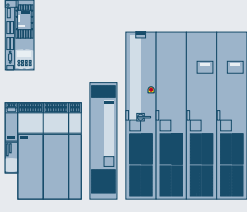
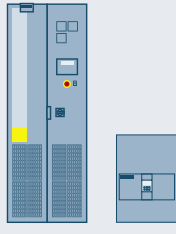
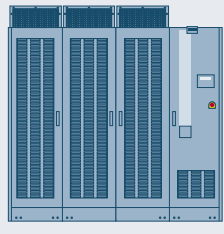
Low voltage AC			DC voltage	Medium voltage AC
Basic Performance	General Performance	High Performance	DC applications	For applications with high power ratings
				
V-series	G-series	S-series	DCM	Medium voltage series
0.12 – 30 kW	0.37 – 6,600 kW	0.12 – 5,700 kW	6 kW – 3 MW	0.15 – 85 MW
When it comes to the hardware as well as the functionality, SINAMICS V converters concentrate on the essentials. This results in a high degree of ruggedness with low associated investment costs.	The functionality of SINAMICS G converters makes them the perfect choice when addressing basic and medium requirements relating to the control dynamic performance.	SINAMICS S converters are predestined for demanding single-axis and multi-axis applications in plant and machinery construction – as well as for the widest range of motion control tasks.	In addition to the highest power ratings, SINAMICS DC converters also offer the maximum degree of availability.	Our seamless and integrated range – which is unique worldwide – encompasses all dynamic response and performance levels in voltage classes 2.3 to 11 kV.

SIMOTICS motors provide you with an ideal solution for any application. They are the most comprehensive range of electric motors worldwide.

SIMOTICS stands for:

- 125 years of experience in building electric motors
- Optimum solutions in all sectors, regions and performance classes
- Innovative motor technologies with the highest quality and reliability
- Highest dynamic performance, precision and efficiency – but still extremely compact

The complete range for all application consists of:

- SIMOTICS low-voltage motors – high-efficiency up to 1250 kW
- SIMOTICS motion control motors – highest dynamic performance and precision
- SIMOTICS DC motors – the pioneers in DC motors
- SIMOTICS high-voltage motors – maximum efficiency and reliability

SINAMICS V90

Optimized servo drive solution for motion control applications

SINAMICS V90 single-axis servo drives

SINAMICS V90 is designed to meet general purpose servo applications, taking into consideration the challenges of machine builders and system integrators regarding costs and time to market.

It is easy to commission the SINAMICS V90 system – essentially just plug & play. Further, it has optimized servo performance, can be quickly integrated into SIMATIC PLC control systems and has a high degree of reliability. A seamless drive system is created by combining SINAMICS V90 servo drive with our SIMOTICS S-1FL6 servomotor.

SINAMICS V90 features internal positioning, positioning with pulse train and speed and torque control modes. With integrated real-time auto tuning and automatic suppression of machine resonances, the system automatically optimizes itself to achieve a high dynamic performance and smooth operation. Further, as a result of the high frequency limit up to 1MHz, the pulse train input facilitates high positioning accuracy.

SINAMICS V-ASSISTANT engineering tool

A PC with installed SINAMICS V-ASSISTANT software tool can be connected to SINAMICS V90 via a standard USB port. It is used for setting parameters, test operation, troubleshooting – and has powerful monitoring functions.



Highlights of the SINAMICS V90 and SIMOTICS S-1FL6 servo drive system:

Optimized servo performance

- Auto tuning enables machines to achieve a high dynamic performance
- Automatic suppression of machine resonances
- 1 MHz high-frequency pulse train input
- Multi-turn absolute encoder with 20-bit resolution

Cost-effective

- Integrated control modes: Pulse train positioning, internal positioning, speed and torque control modes
- Integrated internal positioning function
- Integrated braking resistor in all frame sizes
- Integrated holding brake switch, no external relay necessary

Easy to use

- Easy servo tuning and machine optimization
- Easy commissioning with SINAMICS V-ASSISTANT
- Parameter cloning

Reliable operation

- Wide voltage range 380 V ~ 480 V, -15% / +10%
- High quality motor bearings
- All motors have IP65 degree of protection and are equipped with oil seal
- Integrated safe torque off (STO)
- Reliable drive and motor combination

Power range: 0.4 kW to 7.0 kW

Voltage range: 3AC 380 V ... 480 V (-15% / +10%)

Control modes: Pulse train positioning, internal positioning, speed, torque

SIMOTICS S-1FL6

Optimized servomotor solution for motion control applications

SIMOTICS S-1FL6 servomotors

SIMOTICS S-1FL6 are naturally cooled, permanent-magnet synchronous motors where the heat is dissipated through the motor surface. The motors can be simply and quickly installed using the full thread and quick-release connectors

- 3 shaft heights: 45mm, 65mm, 90mm
- Rated torques from 1.27 Nm up to 33.40 Nm
- Rated speed of 2000 or 3000 rpm
- Incremental encoders TTL 2500 S/R (13-bit resolution) and absolute encoders (20-bit resolution) are available
- Degree of protection IP65, natural cooling
- Optional holding brake
- With plain shaft or feather key

The motors have a 300 percent overload capability and can be combined with the SINAMICS V90 drives to create a powerful servo system with high functionality. Incremental or absolute encoders can be selected depending on the application. SIMOTICS S-1FL6 motors have a high

degree of dynamic performance, wide speed control range and high shaft end and flange precision.

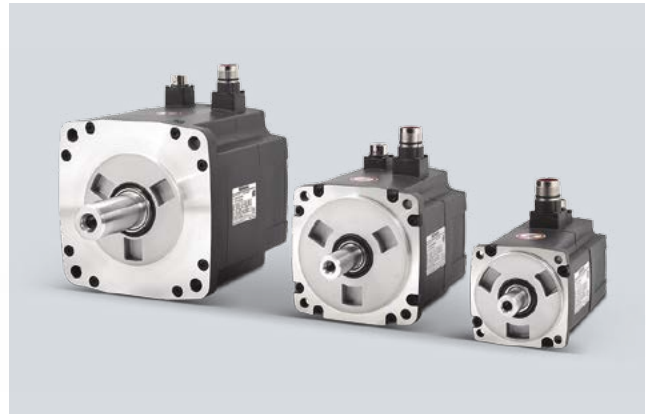

Typical applications

- Handling machines
e.g. pick & place machines
- Packaging machines
e.g. labeling machines
horizontal packaging machines
- Automatic assembly machines
- Metal forming machines
- Printing machines
e.g. screen printing machines
- Winders and unwinders



Cost-effective

Many integrated functions to reduce machine costs

Integrated control modes

Pulse train input position control mode (PTI), internal position control mode (IPos), speed control mode and torque control are all integrated in the SINAMICS V90.

The drive has various integrated control modes to address a wide range of applications.

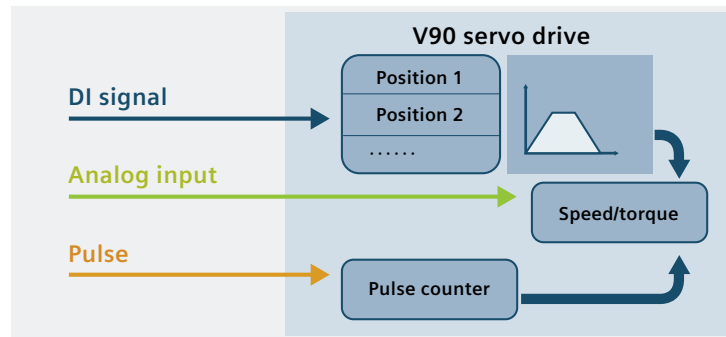

Integrated positioning function

- Position, speed, and acceleration setpoints can be entered
- Integrated referencing function
- Feed forward and feed backward – or a combination of digital inputs to select position
- Positioning step enable from external digital input
- Absolute and relative positioning

Point-to-point positioning possible using a PLC without positioning functionality.

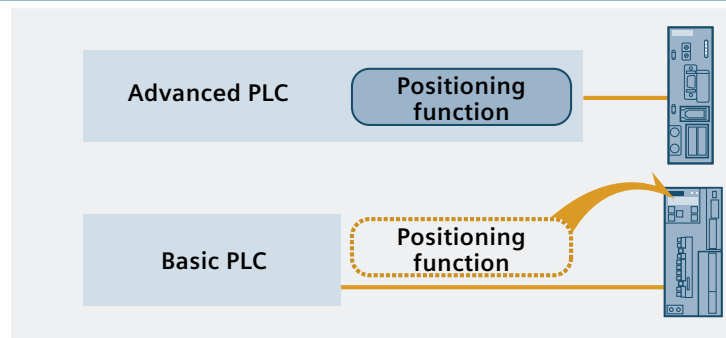

Integrated braking resistor for all frame sizes

Braking resistor is integrated for all frame sizes to dissipate the regenerative power for fast braking.

Most applications can be realized without an additional braking resistor.

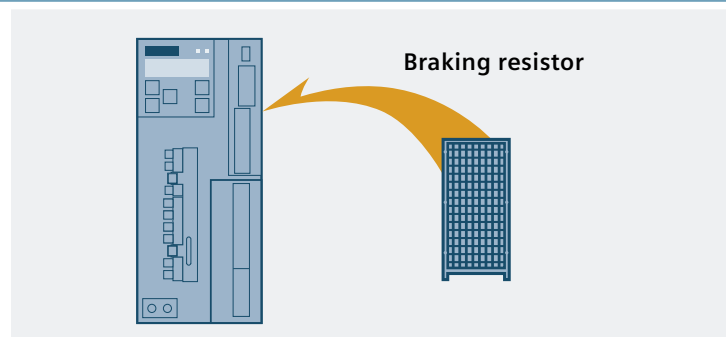

Integrated holding brake switch

Integrated holding brake switch – the brake can be directly connected to the drive if a motor with holding brake is used.

Holding brake can be connected without requiring an external relay.

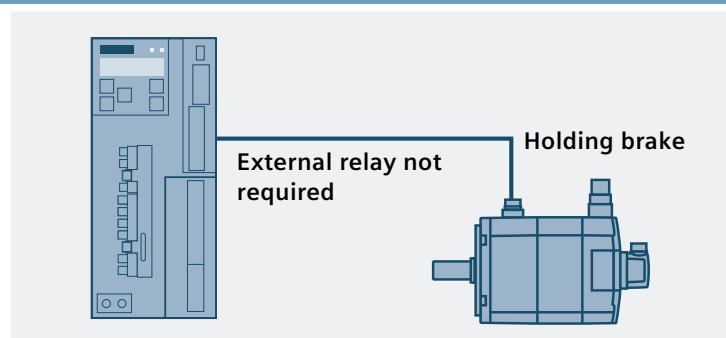

Optimized servo performance

Quick, smooth and precise positioning

Advanced auto tuning

Control loop parameters are optimized automatically. This function can be used when commissioning the system and in operation for changing loads.

This allows machines to achieve a high dynamic performance and smooth operation in a wide range of applications.

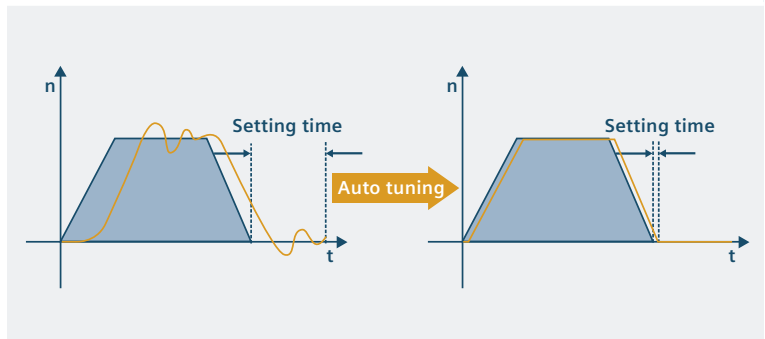

Automatic suppression of machine resonances

When this function is activated the drive identifies mechanical resonance frequencies and automatically suppresses these using a filter. Vibration and noise during operation are reduced.

This ensures a high dynamic response of the machine while decreasing machine vibration.

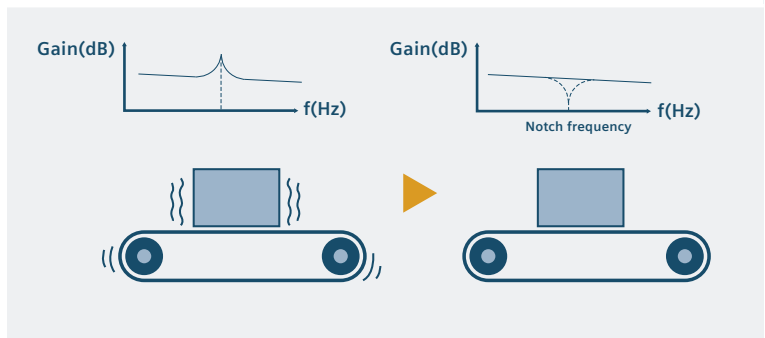

1MHz pulse train setpoint and 20-bit encoder resolution

The command pulse train input operate at the high frequency up to 1MHz and the feedback absolute encoder available with 20 bit resolution.

Makes the machine to reach high positioning accuracy and low speed ripple.

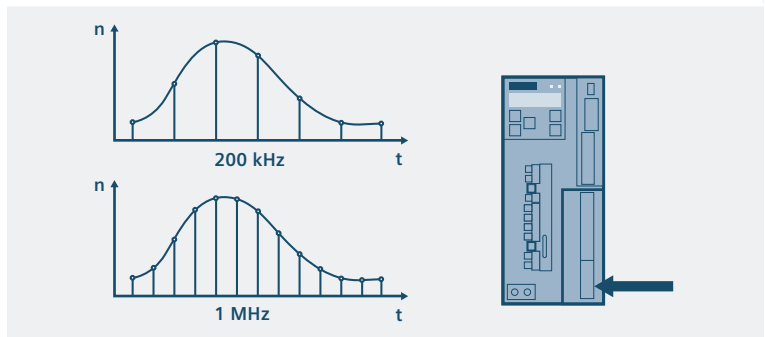

Optimized system performance

- 300 percent overload capability of drive and motor
- Low motor torque ripple
- Motor and drive are perfectly coordinated with one another

Fast acceleration and braking while maintaining a smooth running system to ensure high machine productivity.

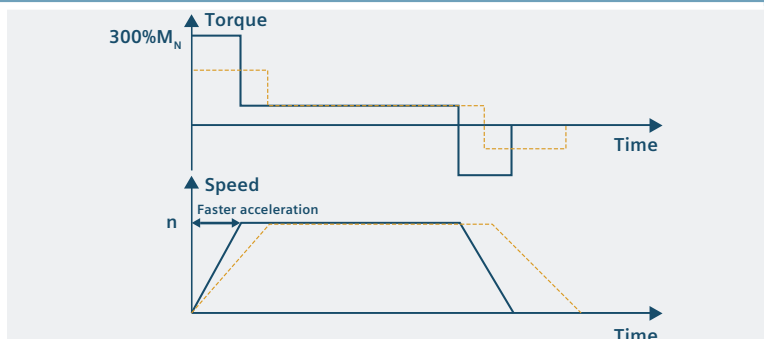

Easy to use

Simple tuning and quick commissioning

Easy servo tuning and machine optimization

The system can be automatically optimized using the auto tuning function and automatic suppression of machine resonances.

Simply plug & play, no in-depth servo know-how required.

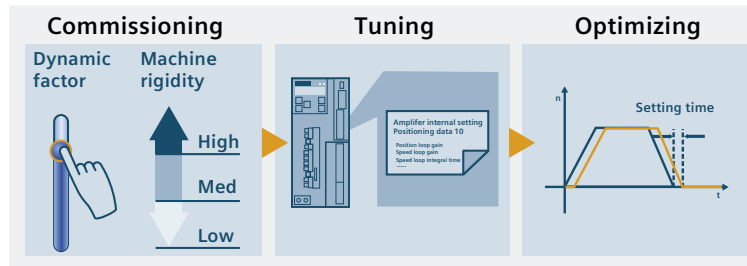

Easy commissioning using the SINAMICS V-ASSISTANT engineering tool

Graphic screen forms guide the user when setting application-specific parameters; intuitive drive and motor status check; integrated trace and measuring functionality.

SINAMICS V-ASSISTANT makes commissioning and diagnostics quick and easy.

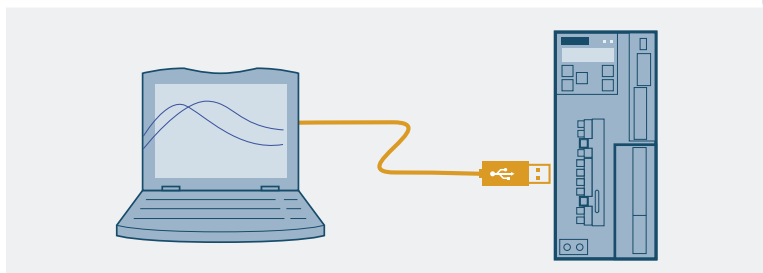

Simple connection to a control system

Two channel pulse train for position setpoint, one exclusively for 5V differential (RS422 standard), one for 24V single ended signal.

Standard interface makes it easy to couple the drive with PLCs and motion controllers.

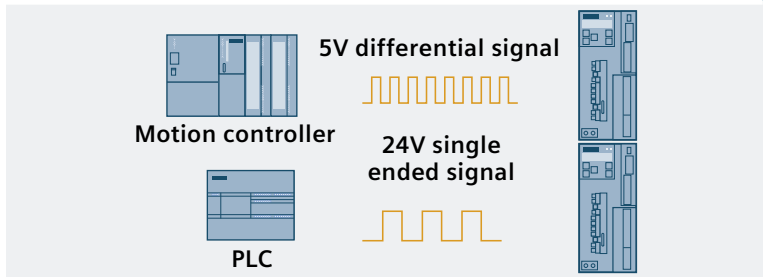

Optimized connection system for easy use

- Orientable connectors on motor side
- Quick-release coupling for encoder and brake connectors (bayonet lock)
- Coded connectors for protection against polarity reversal
- Easy cable selection and ordering system

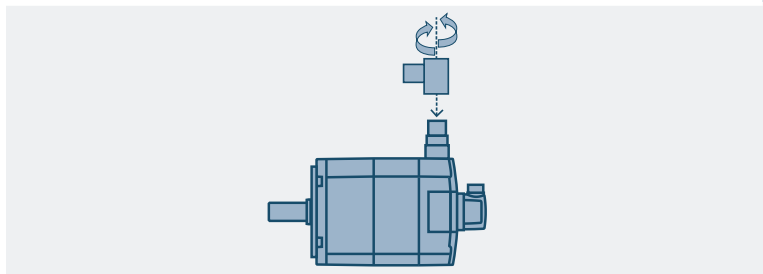

Parameter cloning

SINAMICS V90 servo drives have a standard SD card slot, parameter setting can be easily transferred between drive devices.

Efficient commissioning of serial machines.

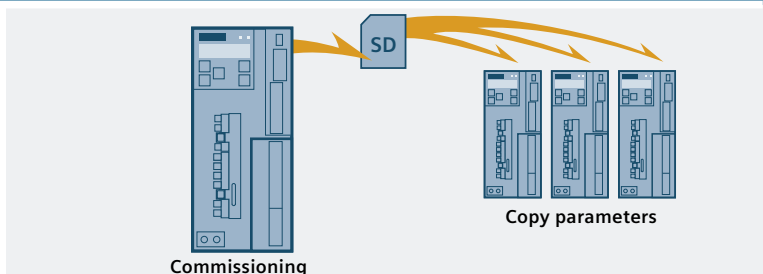

Reliable operation

Robust design and safe choice

Can withstand harsh environments

- Wider voltage range 380 V ~ 480 V, -15% / +10%
- Coated PCB increases robustness of the drive to cope with harsh environments
- Motor is equipped with high-quality bearings

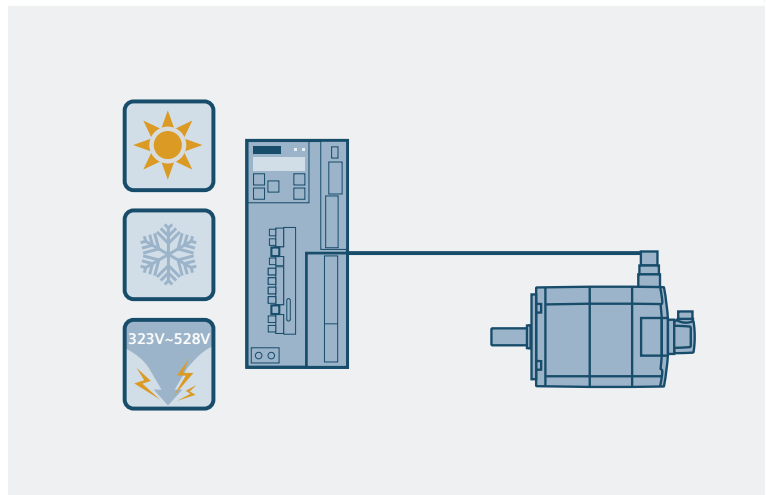

High degree of motor protection

- SIMOTICS S-1FL6 motors have degree of protection IP65 as standard - this includes the connectors on motor side
- Oil seal at shaft end as standard
- High quality metal motor connector

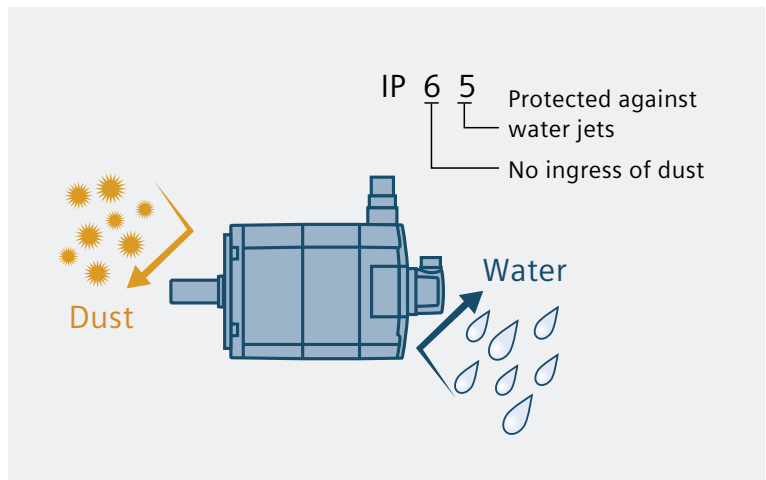

Integrated safety function STO (safe torque off)

The STO (safe torque off) function is a standard feature of all SINAMICS V90 servo drives. This function prevents the motor from moving unexpectedly and complies with safety standard SIL2 (EN618005-2). This safety functionality can be realized without additional components.

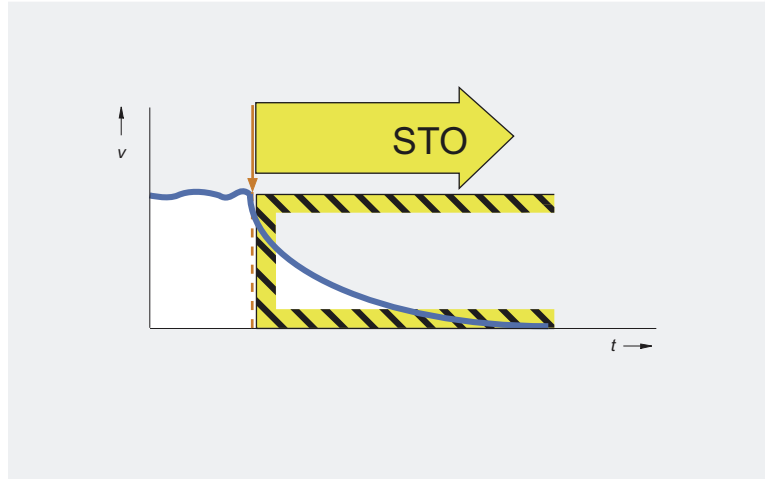

SINAMICS V-ASSISTANT

Easy-to-use engineering tool for commissioning and diagnostics

- Intuitive menu navigation provides a clear overview of the commissioning workflow
- Simple commissioning with point-to-point communication via USB interface
- Graphic screen forms guide the user when setting application-specific parameters
- High degree of usability:
 - compact
- can be downloaded from the SINAMICS V90 internet page: www.siemens.com/sinamics-v90
- languages can be toggled on-the-fly
- Advanced tools such as the trace function, machine-measuring function, servo tuning function and control panel are available to optimize the machine performance and for diagnostics
- Convenient data handing for commissioning series machines and archiving different machine versions

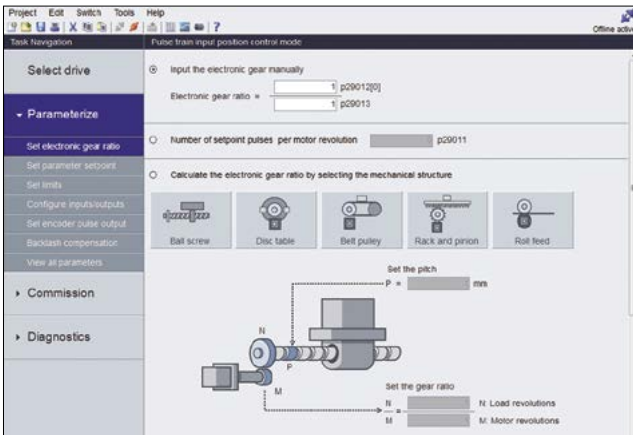

User task-centric design for prompted machine commissioning

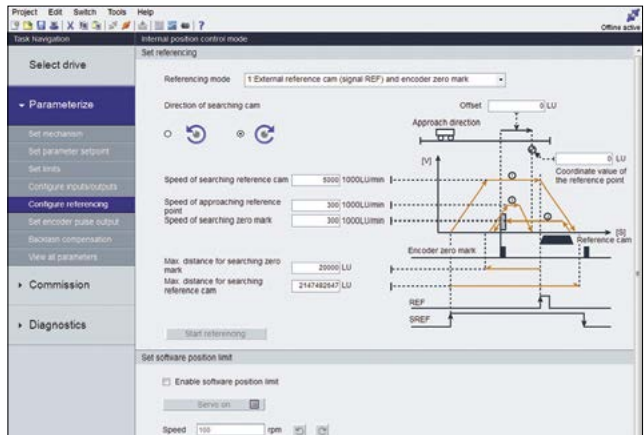

Graphic screen so that users can quickly and simply configure machines

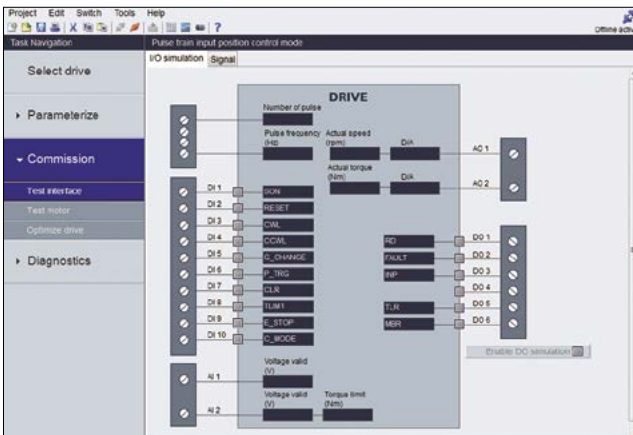

Graphic view to monitor the digital inputs/outputs and other control signals

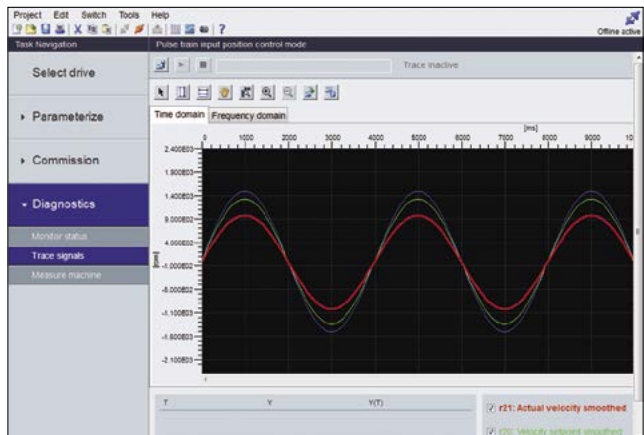

Trace function to monitor the drive and motor status

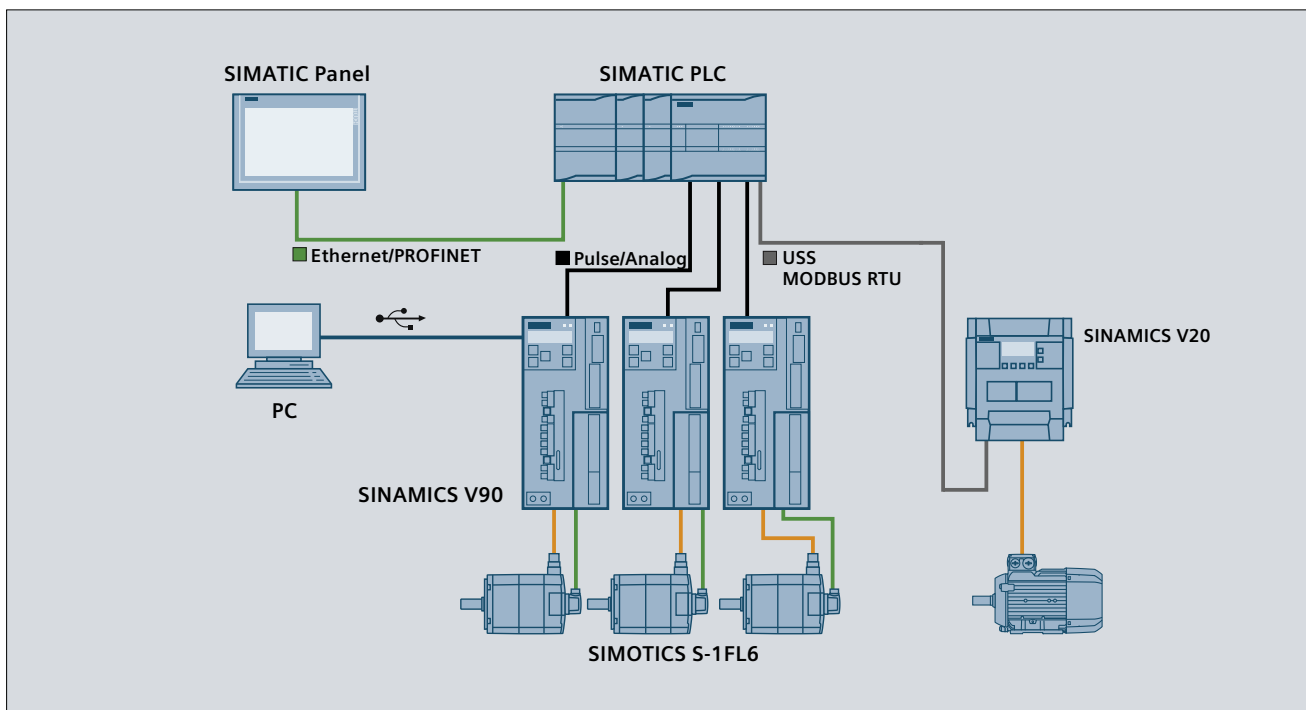

Complete solution for motion control applications

With SINAMICS V90 and SIMOTICS S-1FL6, the optimized servo drive system – together with SIMATIC Panel, SIMATIC PLC and SINAMICS V20 – SIEMENS is offering comprehensive solutions from a single source for general motion control applications. Typical sectors include textiles, packaging, material handling – as well as many others.



SINAMICS V90

Technical data

Technical data									
Article No.	6SL3210-5FE	10-4UA0	10-8UA0	11-0UA0	11-5UA0	12-0UA0	13-5UA0	15-0UA0	17-0UA0
Frame size		FSAA	FSA		FSB		FSC		
Rated power (kW)		0.40	0.75	1.00	1.50	2.00	3.50	5.00	7.00
Rated output current (A)		1.2	2.1	3.0	5.3	7.8	11.0	12.6	13.2
Max. output current (A)		3.6	6.3	9.0	15.9	23.4	33.0	37.8	39.6
Line supply	Voltage	3AC 380V ... 480V, (-15% / +10%)							
	Frequency	50/60Hz, (-10% / +10%)							
	Capacity (kVA)	1.7	3.0	4.3	6.6	11.1	15.7	18.0	18.9
Control power supply	Voltage (V) ¹⁾	24 DC (-15% / +20%)							
	Current (A)	1.6 (without holding brake), 3.6 (with holding brake)							
Line supply system		TN, TT, IT, TT earthed line							
Overload capacity		300% x rated current for 300ms every 10s							
Control system		Servo control							
Braking resistor		Integrated							
Ambient temperature	Operation	0 °C to 45 °C, without power derating 45 °C to 55°C, with power derating up to 20% at 55 °C							
	Storage	-40°C to +70°C							
Ambient humidity	Operation	< 90% (no condensation)							
	Storage	90% (no condensation)							
Pollution class		2							
Vibration severity	In operation	≤ 1 g (g=9,81 m/s ²)							
	During transport	≤ 2 g (g=9,81 m/s ²)							
Degree of protection		IP20							
Cooling		Natural cooling				Fan cooling			
Altitude		≤ 1000 m (without power derating); > 1000 m and up to 5000 m (with power derating)							
Weight approx. (kg)		1.5 kg	2.1 kg		2.7 kg		5.9 kg		
Standards		   cULus, C-tick							
Interface									
USB		Mini USB							
Pulse train input		2 channel, one exclusively for 5V differential signal, one for 24V single ended signal							
Pulse train encoder output		5 V differential signal, phases A, B, Z							
Digital inputs/outputs		10 inputs, NPN/PNP; 6 outputs, sink type							
Analog inputs		2 analog inputs, input voltage range +/-10V, 13-bit							
Analog outputs		2 analog outputs, output voltage range +/-10V, 10-bit							

¹⁾ When SINAMICS V90 controls a motor equipped with brake, the tolerance of the 24 V DC power supply must be -10% to +10% to comply with the voltage required by the brake.

SINAMICS V90

Control features

Control features		
Control modes		<ul style="list-style-type: none"> • Pulse train input position control (PTI), with torque and speed limit • Internal position control (IPos), setpoints selected using a combination of digital inputs (traversing blocks) • Speed control (S), via analog input or fixed internal speed setpoint, with torque limit • Torque control (T), via analog input or fixed internal torque setpoint, with speed and torque limits • Control mode switchover, e.g. switchover from position control to speed control on-the-fly via digital input • Jog using buttons on the integrated operator panel (BOP)
Speed control mode	Speed control range	Analog speed command: 1:2000 Internal speed command:1:5000
	Analog speed input	-10 V DC to +10 V DC/rated speed
	Torque limit	Set using a parameter or an analog input command
Pulse train input position control	Max. input pulse frequency	High-speed differential line driver (5V), 1MHz optocoupler(24V), 200kHz
	Multiplying factor	Electronic gear ratio (A/B), A:1-65535, B:1-65535, 1/50<A/B<200
	In-position range	0 to ±1000pulse(command pulse unit)
Torque control	Torque limit	Set using a parameter or analog input command
	Analog torque input	-10 V DC to +10 V DC/max. torque (input impedance >25 kΩ)
Control functions	Speed limit	Set using a parameter or an analog input command
	Real time auto tuning	Estimates the machine characteristic and sets the closed loop control parameters (gain, integral, etc.) continuously in real time without any user intervention
	Resonance suppresses	Suppress the mechanical resonance, such as workpiece and foundation vibration
	One-button tuning	Optimizes the control parameters such as position loop gain, speed loop gain, speed loop integral time, mechanical resonance frequency etc. by just clicking one button on the operator panel or SINAMICS V-ASSISTANT
	Gain switch	Switches between gains using an ext. signal or int. operating conditions to reduce noise, shorten positioning time and improve the operational stability of a servo system
	PI/P control switch	Switches from PI control to P control with an external signal or internal operating conditions
	Speed and torque limit	Limits motor speed using an external analog speed limit command (0 to ±10 V DC) or internal speed limit commands (up to three groups)
	DI/DO parameterization	Freely assigns the control signals to 8 digital inputs and 6 digital output
	External braking resistor	An external braking resistor can be used when the internal braking resistor is not capable of handling the regenerative energy
	Position smoothing	Transforms position characteristics from the pulse train input setpoint into an S-curve profile with a parameterized time constant
Measuring machine function	The machine frequency characteristics are analyzed using SINAMICS V-ASSISTANT	
Zero speed clamp	Stops motor and locks motor axis when motor speed setpoint is below a parameterized threshold level	
SD card	SD card for parameter cloning and FW update	
Safety functions	Safe torque off (STO) via terminal	
Operator Panel (OP)	Integrated, 6-digit / 7-segment display, 5 buttons	
PC tool	SINAMICS V-ASSISTANT engineering tool exclusively for SINAMICS V90	

SINAMICS V90

Connection diagram

Standard wiring for pulse train input (PTI) position control mode (detailed information and connection diagram for other control modes, please refer to the operating instructions). The diagram shown is given as a reference for selecting the drive type. When using the selected servo drive system, establish the wiring connections according to the connection diagram and the instructions provided in the users manual.

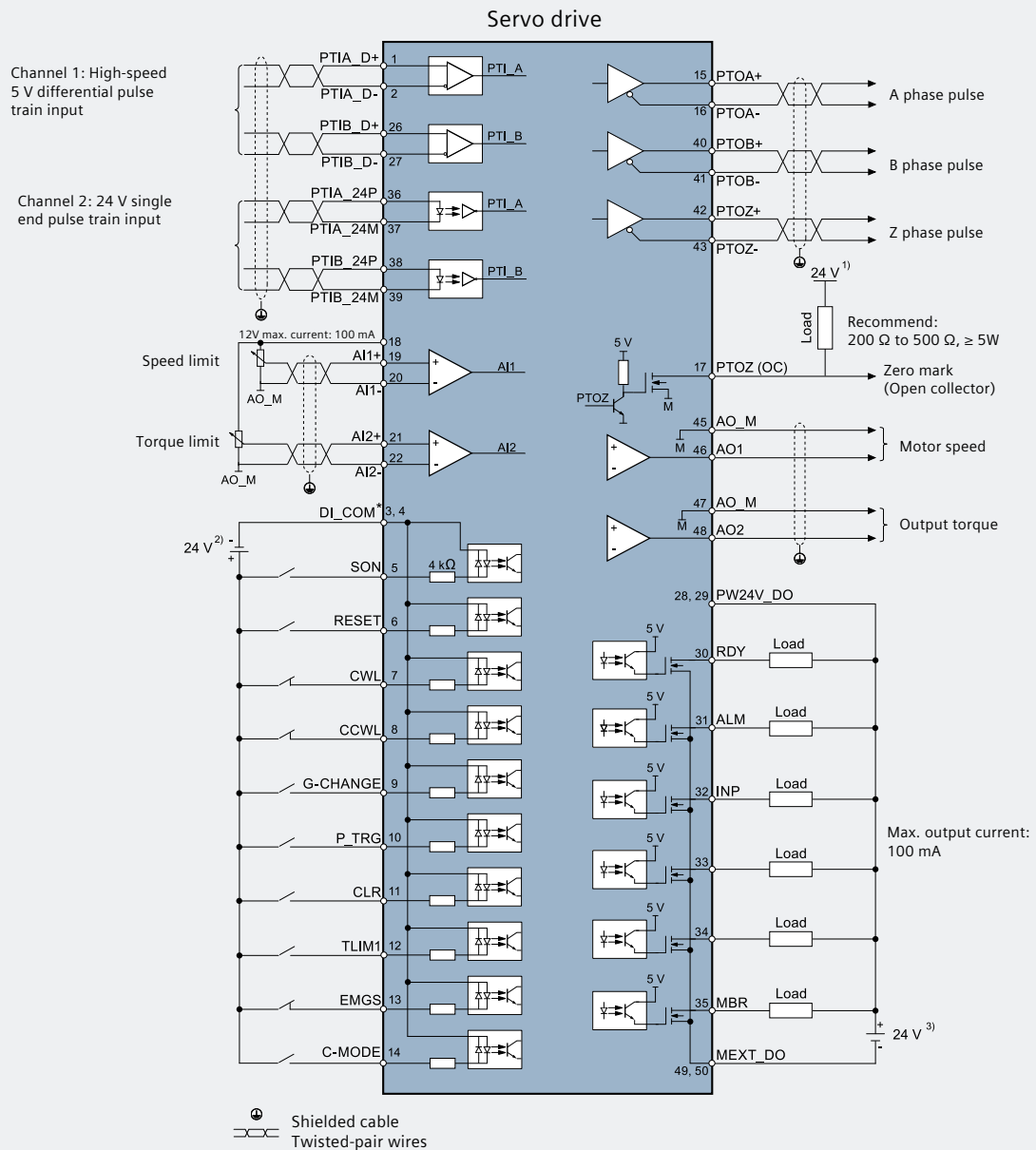

Other control signals can be assigned to digital inputs and 6 digital outputs, please refer to the operating instructions.

* Digital inputs, supporting both PNP and NPN types.

The 24 V power supplies in the connection diagram are as follows:

- 1) 24 V power supply for SINAMICS V90. All the PTO signals must be connected to the controller with the same 24 V power supply as SINAMICS V90.
- 2) Isolated digital input power supply. It can be the controller power supply.
- 3) Isolated digital output power supply. It can be the controller power supply.

SINAMICS V90

Dimensions and mounting clearances

Dimension drawings (mm)

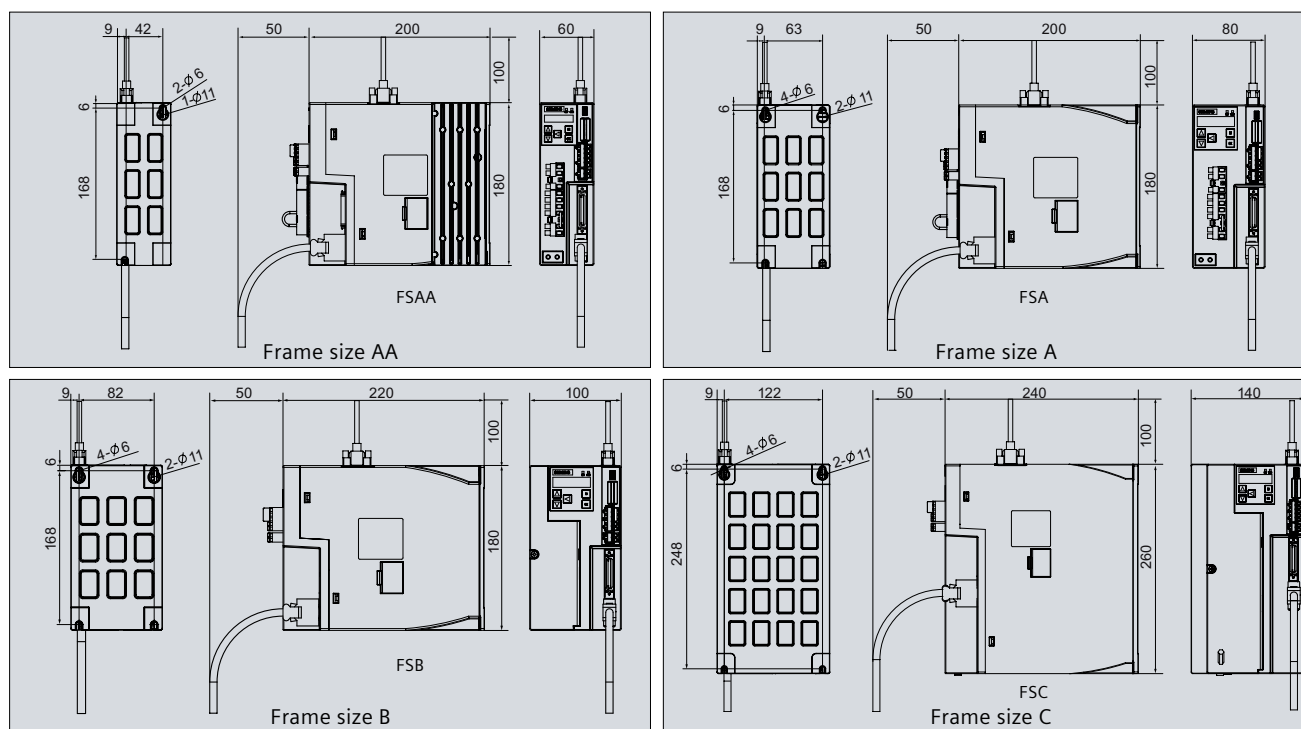

Mounting clearances (mm)

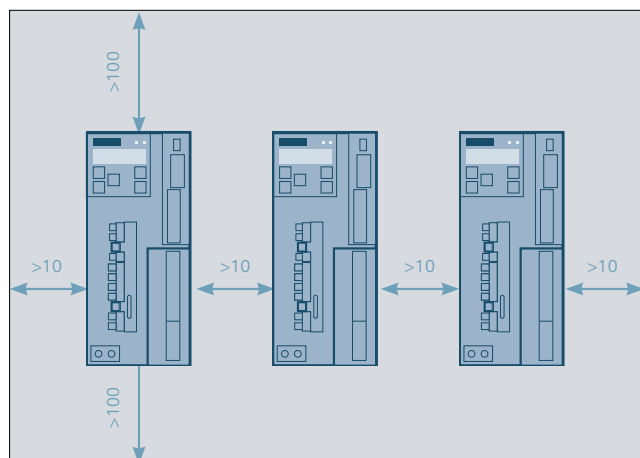

Dimensions¹⁾ and weight

Frame size	Width (mm)	Height (mm)	Depth (mm)	Weight (kg)
FSA	60	180	200	1.45
FSA	80	180	200	2.09
FSB	100	180	220	2.73
FSC	140	260	240	5.95

¹⁾ All dimensions refer to the maximum outer dimension

SIMOTICS S-1FL6

Technical data

Technical data											
Article number 1FL6	042– 1AF	044– 1AF	061– 1AC	062– 1AC	064– 1AC	066– 1AC	067– 1AC	090– 1AC	092– 1AC	094– 1AC	096– 1AC ²
Shaft height (SH)	45		65				90				
Rated power (kW) ¹	0.40	0.75	0.75	1.00	1.50	1.75	2.00	2.50	3.50	5.00	7.00
Horsepower (HP)	0.54	1.02	1.02	1.36	2.04	2.38	2.72	3.40	4.76	6.80	9.52
Rated torque (Nm)	1.27	2.39	3.58	4.78	7.16	8.36	9.55	11.90	16.70	23.90	33.40
Rated speed (rpm)	3000		2000				2000				
Maximum torque (Nm) ¹	3.8	7.2	10.7	14.3	21.5	25.1	28.7	35.7	50.0	70.0	90.0
Maximum speed (r/min)	4000		3000				3000			2500	2000
Rated current (A)	1.2	2.1	2.5	3.0	4.6	5.3	5.9	7.8	11.0	12.6	13.2
Maximum current (A)	3.6	6.3	7.5	9.0	13.8	15.9	17.7	23.4	32.9	36.9	35.6
Torque constant (Nm/A)	1.1	1.2	1.5	1.7	1.6	1.7	1.7	1.6	1.6	2.0	2.7
Moment of inertia (10 ⁻⁴ kg·m ²) (with brake)	2.7 (3.2)	5.2 (5.7)	8.0 (9.1)	15.3 (16.4)	15.3 (16.4)	22.6 (23.7)	29.9 (31.0)	47.4 (56.3)	69.1 (77.9)	90.8 (99.7)	134.3 (143.2)
Thermal class	B (130°C)										
Degree of protection	IP65										
Recommended load to motor inertia ratio	Max. 10x		Max. 5x				Max. 5x				
Encoder types	Incremental encoder TTL 2500 S/R, absolute encoder 20-bit single-turn + 12-bit multi-turn										
Type of construction	IM B5 (IM V1 and IM V3)										
Weight (kg) ⁴ (with brake)	3.3 (4.6)	5.1 (6.4)	5.6 (8.6)	8.3 (11.3)	8.3 (11.3)	11.0 (14.0)	13.6 (16.6)	15.3 (21.3)	19.7 (25.7)	24.3 (30.3)	33.2 (39.1)
Operating temperature	0 ~ 40 °C (without any restrictions)										
Operating humidity	90% RH maximum (no condensation at 30°C)										
Vibration severity grade	Grade A										
Radial runout tolerance	N										
Installation altitude	≤ 1000 m (without power derating); > 1000 m and up to 5000 m (with power derating)										
Standards											
Holding brake data ³											
Holding torque (Nm)	3.5		12.0				30.0				
Rated voltage (V)	24V DC ±10%										
Opening time (ms)	60		180				220				
Closing time (ms)	45		60				115				
Rated current (A)	0.9		1.5				1.9				

1) The data of rated torque, rated power and maximum torque in the table above allow a tolerance of 10%, due to production tolerances.

2) For 1FL6096 motor with brake, when the ambient temperature is more than 30°C, the power should be derated by 10%.
Power derating is not required for other motors.

3) It is not permissible to use the holding brake for an emergency stop.

4) Motor weight with incremental encoder

SIMOTICS S-1FL6

Torque-speed characteristic when connected to SINAMICS V90

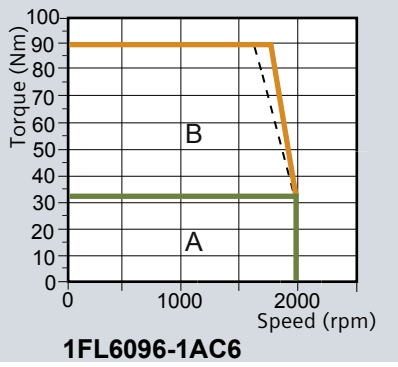
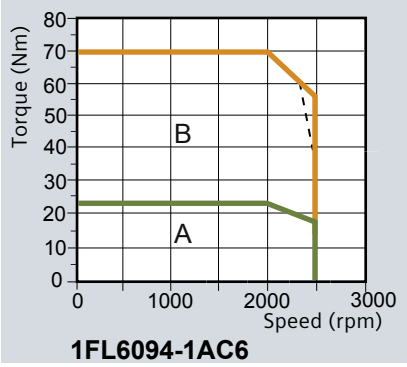
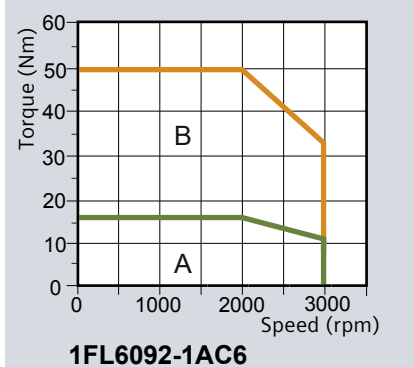
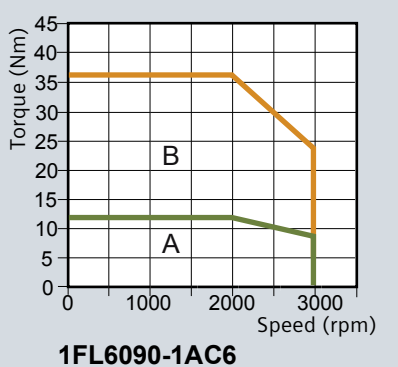
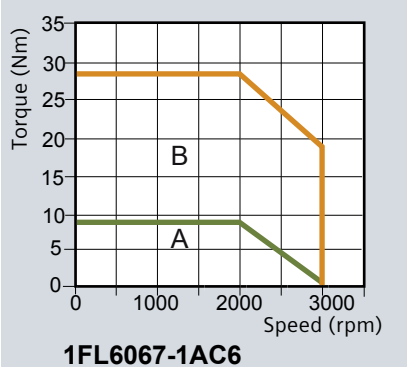
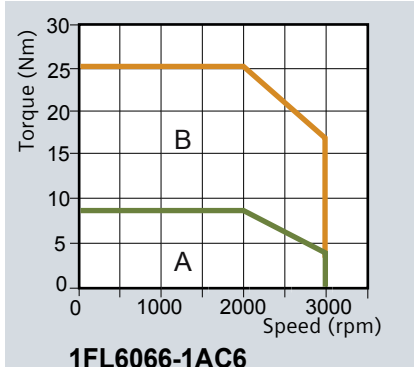
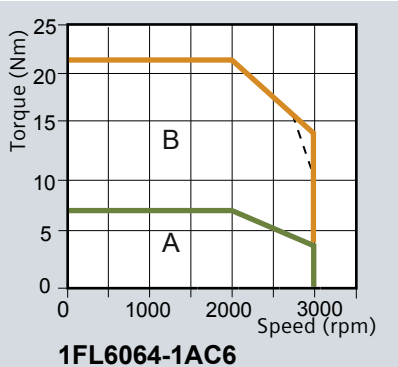
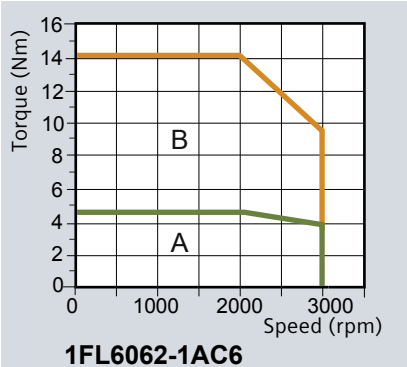
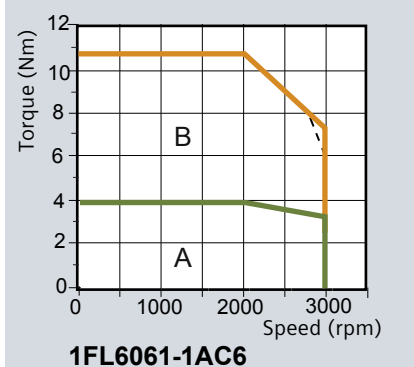
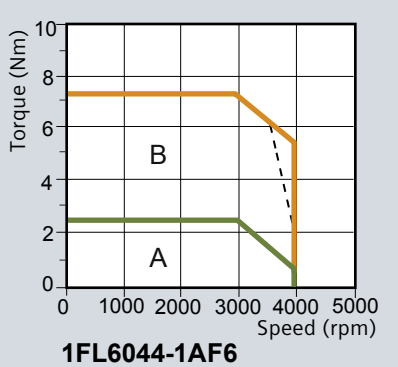
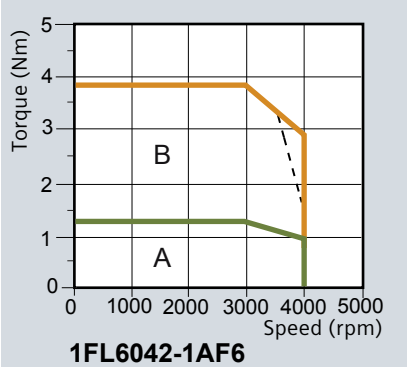

Notes:
 A: Continuous operating area
 B: Short-term operating area
 — : Supply voltage 400V
 - - - : Supply voltage 380V

SIMOTICS S-1FL6

Dimension drawings

Motor with incremental encoder (dimensions in mm)

Shaft																Without brake			With brake						
height	Type	LC	LA	LZ	N	LR	T	LG	D	DB	E	QK	GA	F	LB	KB1	KB2	LB	KB1	KB2	KL1	KL2	KL3	KL4	
45	1FL6042	90	100	7	80	35	4	10	19	M6x16	30	25	21.5	6	154,5	93,5	-	201	140	31,5	129	92	-	-	
	1FL6044	90	100	7	80	35	4	10	19	M6x16	30	25	21.5	6	201,5	140,5	-	248	187	31,5	129	92	-	-	
65	1FL6061	130	145	9	110	58	6	12	22	M8x16	50	44	25	8	148	85,5	-	202,5	140	39,5	151	115	23	22	
	1FL6062	130	145	9	110	58	6	12	22	M8x16	50	44	25	8	181	118,5	-	235,5	173	39,5	151	115	23	22	
	1FL6064	130	145	9	110	58	6	12	22	M8x16	50	44	25	8	181	118,5	-	235,5	173	39,5	151	115	23	22	
	1FL6066	130	145	9	110	58	6	12	22	M8x16	50	44	25	8	214	151,5	-	268,5	206	39,5	151	115	23	22	
	1FL6067	130	145	9	110	58	6	12	22	M8x16	50	44	25	8	247	184,5	-	301,5	239	39,5	151	115	23	22	
90	1FL6090	180	200	13.5	114.3	80	3	18	35	M12x25	75	60	38	10	189,5	140	-	255	206	44,5	177	149	34	34	
	1FL6092	180	200	13.5	114.3	80	3	18	35	M12x25	75	60	38	10	211,5	162	-	281	232	44,5	177	149	34	34	
	1FL6094	180	200	13.5	114.3	80	3	18	35	M12x25	75	60	38	10	237,5	188	-	307	258	44,5	177	149	34	34	
	1FL6096	180	200	13.5	114.3	80	3	18	35	M12x25	75	60	38	10	289,5	240	-	359	310	44,5	177	149	34	34	

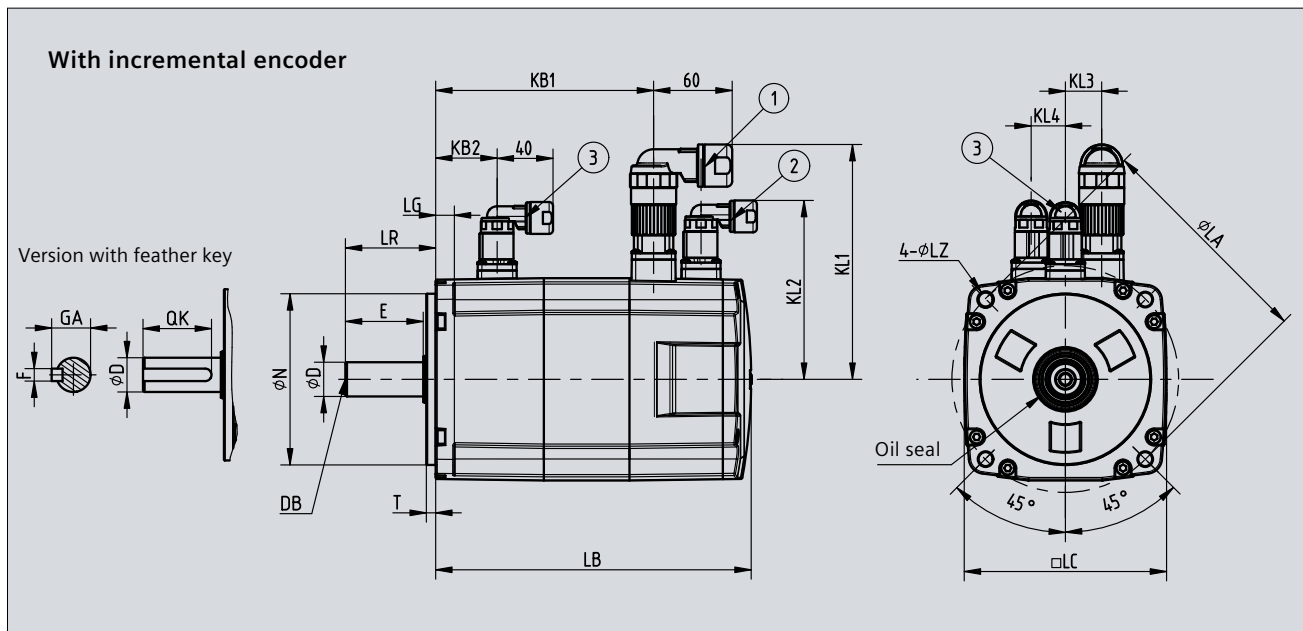

- Note:**
- 1) ① Power connector, ② Incremental encoder connector, ③ Brake connector
Connectors should be ordered separately, for ordering information please refer to section "Options" in this document.
 - 2) Outline dimensions of ② incremental encoder connector ③ brake connector are the same.
 - 3) Shaft height 90 motor has M8 screws for eyebolts.

Dimension drawings

Motor with absolute encoder (dimensions in mm)

Shaft																Without brake			With brake						
height	Type	LC	LA	LZ	N	LR	T	LG	D	DB	E	QK	GA	F	LB	KB1	KB2	LB	KB1	KB2	KL1	KL2	KL3	KL4	
45	1FL6042	90	100	7	80	35	4	10	19	M6x16	30	25	21.5	6	157	100	-	203,5	147	31,5	129	60	-	-	
	1FL6044	90	100	7	80	35	4	10	19	M6x16	30	25	21.5	6	204	147	-	250,5	194	31,5	129	60	-	-	
65	1FL6061	130	145	9	110	58	6	12	22	M8x16	50	44	25	8	151	92	-	205,5	147	39,5	151	60	-	-	
	1FL6062	130	145	9	110	58	6	12	22	M8x16	50	44	25	8	184	125	-	238,5	180	39,5	151	60	-	-	
	1FL6064	130	145	9	110	58	6	12	22	M8x16	50	44	25	8	184	125	-	238,5	180	39,5	151	60	-	-	
	1FL6066	130	145	9	110	58	6	12	22	M8x16	50	44	25	8	217	158	-	271,5	213	39,5	151	60	-	-	
	1FL6067	130	145	9	110	58	6	12	22	M8x16	50	44	25	8	250	191	-	304,5	246	39,5	151	60	-	-	
90	1FL6090	180	200	13.5	114.3	80	3	18	35	M12x25	75	60	38	10	197	135	-	263	201	44,5	177	60	-	-	
	1FL6092	180	200	13.5	114.3	80	3	18	35	M12x25	75	60	38	10	223	161	-	289	227	44,5	177	60	-	-	
	1FL6094	180	200	13.5	114.3	80	3	18	35	M12x25	75	60	38	10	249	187	-	315	253	44,5	177	60	-	-	
	1FL6096	180	200	13.5	114.3	80	3	18	35	M12x25	75	60	38	10	301	239	-	367	305	44,5	177	60	-	-	

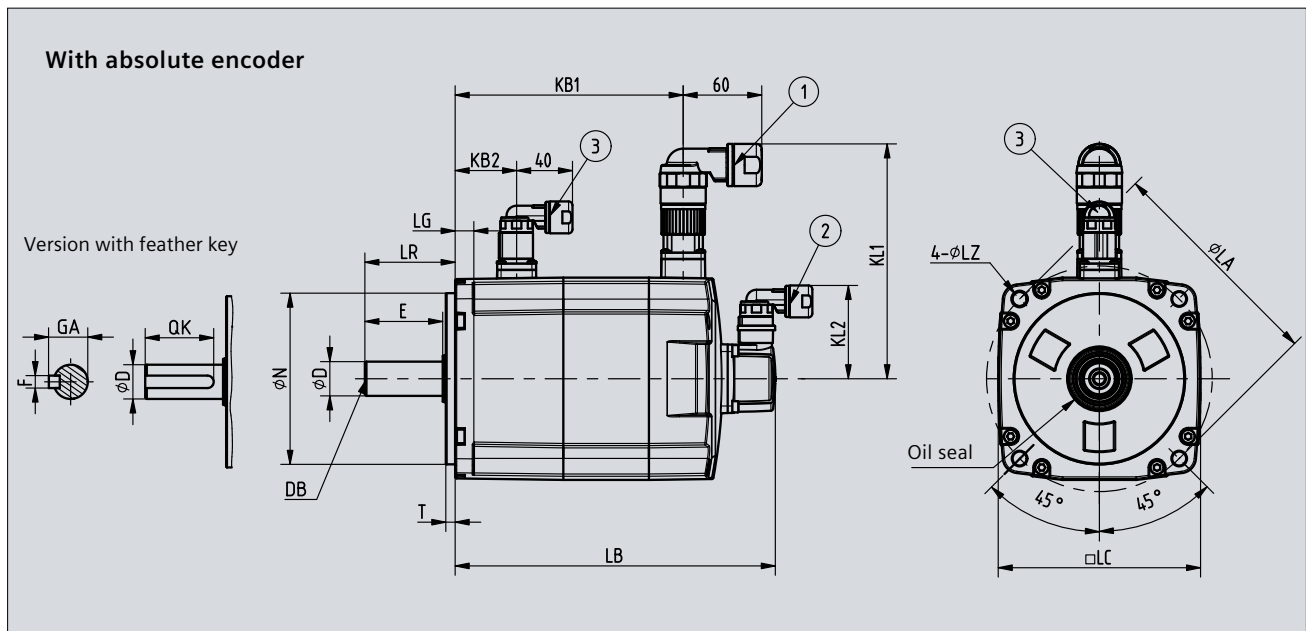

- Note:**
- 1) ① Power connector, ② Absolute encoder connector, ③ Brake connector
Connectors should be ordered separately, for ordering information please refer to section "Options" in this document.
 - 2) Outline dimensions of ② absolute encoder connector ③ brake connector are the same.
 - 3) Shaft height 90 motor has M8 screws for eyebolts.

System at a glance

Status indicator

- RDY indicates the servo ready/alarm
- COM indicates communication with PC

Integrated Operator Panel

- 6 digits, 7-segment LED
- 5 buttons

High quality safety connectors

Braking resistor

- If internal braking resistor is not sufficient, disconnect DCP and R2, then connect DCP and R1 with an external braking resistor

Shield plate

- Easy to attach cables and better EMC performance

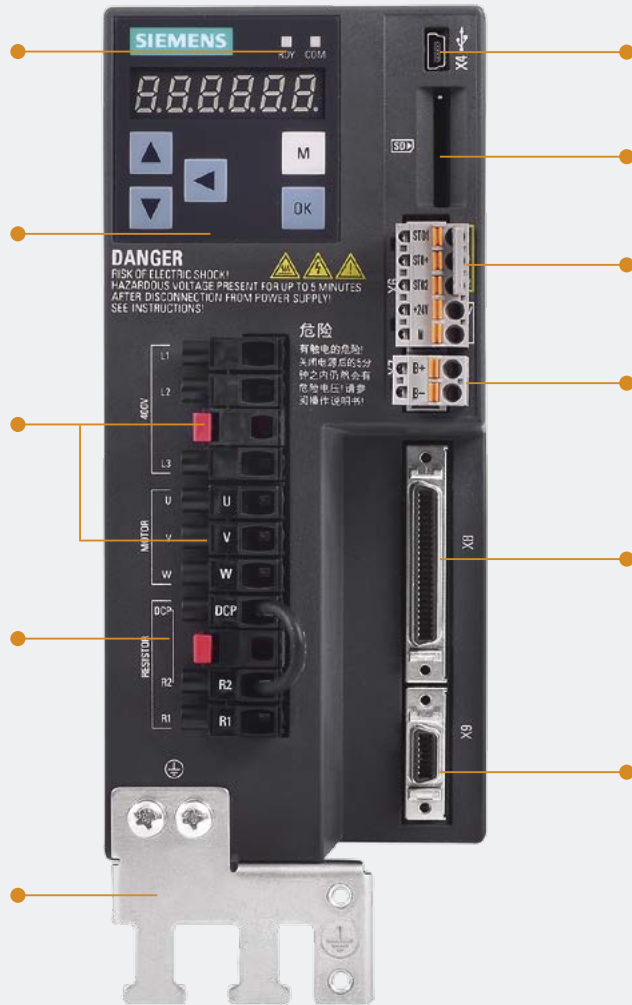

Standard mini USB

- To connect a PC with engineering tool

SD card slot

- To copy parameters

Safe Torque off

- Safe torque off function

Motor holding brake

- Motor holding brake can be connected without external relay

Control/status interface

- 50 pins
- Pulse train input
- Encoder emulation pulse output
- DI/DO, AI/AO

Small encoder connector

Quick release connector

IP65 as standard for all motors

High wear-resistant oil seal material

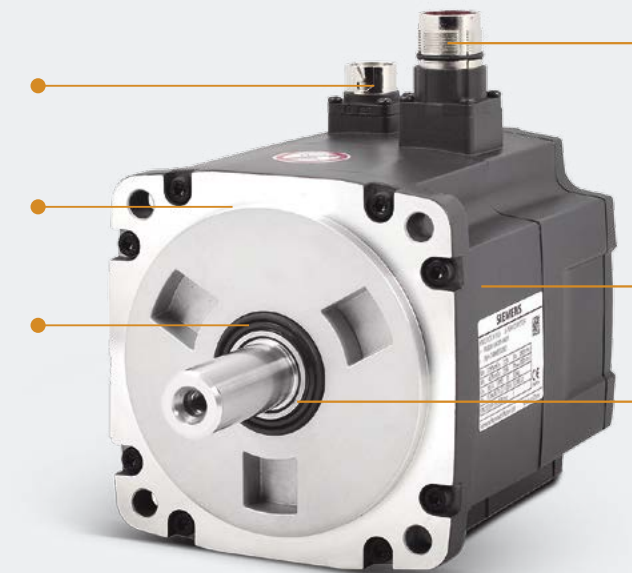

High quality metal connector

High-quality bearings

Shaft sleeve protection

System connection diagram

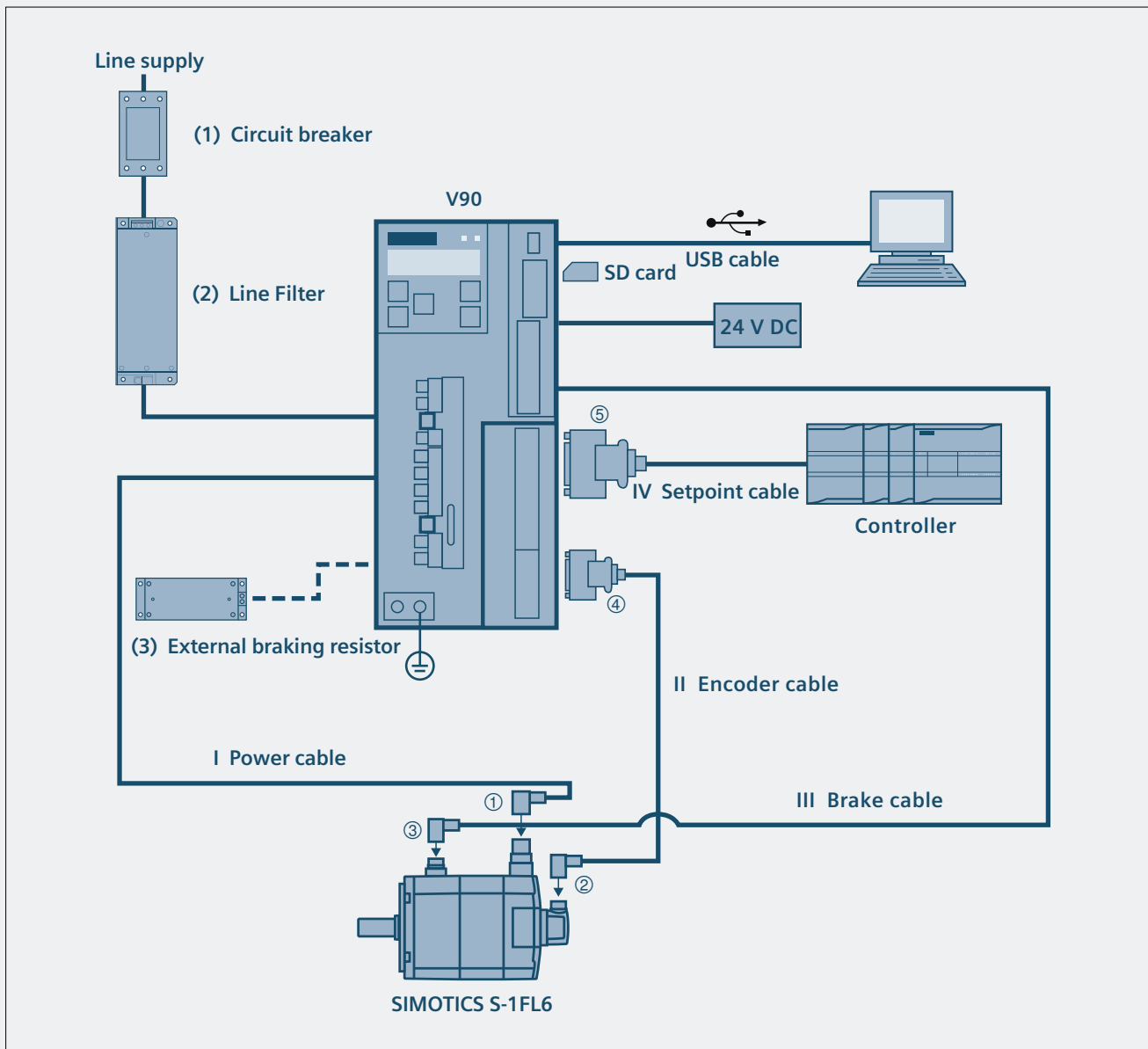

(1)	Circuit breaker
(2)	Line filter
(3)	External braking resistor
I	Power cable
II	Encoder cable
III	Brake cable
IV	Setpoint cable

①	Power connector (motor side)
②	Encoder connector (motor side)
③	Brake connector (motor side)
④	Encoder connector (drive side)
⑤	Setpoint connector

SINAMICS V90 and SIMOTICS S-1FL6

Ordering information

SINAMICS V90 servo drive



6SL3210 - 5F E 17 - 0 UAO

Symbol	Line supply voltage
E	380...480 3AC

Symbol	Rated power of supported servomotor
10 - 4	0.40 kW
10 - 8	0.75 kW
11 - 0	1.00 kW
11 - 5	1.50 kW
12 - 0	2.00 kW
13 - 5	3.50 kW
15 - 0	5.00 kW
17 - 0	7.00 kW

SIMOTICS S-1FL6 servomotor



1FL6 06 7- 1A C 61 - 0 A H 1

Symbol	Shaft height
04	45
06	65
09	90

Symbol	Shaft version
A	Feather key, without holding brake
B	Feather key, with holding brake
G	Plain shaft, without holding brake
H	Plain shaft, with holding brake

Symbol	Rated torque
04 2	1.27 Nm
04 4	2.39 Nm
06 1	3.58 Nm
06 2	4.78 Nm
06 4	7.16 Nm
06 6	8.36 Nm
06 7	9.55 Nm
09 0	11.90 Nm
09 2	16.70 Nm
09 4	23.90 Nm
09 6	33.40 Nm

Symbol	Rated speed
C	2000 rpm
F	3000 rpm

Symbol	Encoder types
A	Incremental TTL 2500 S/R
L	Absolute 20-bit



ARCO CONTROL

☎ :051-57133855-6

☎ :09014284236

WWW.ARCOKALIA.COM

SIMOTICS S-1FL6					SINAMICS V90		
Rated Power (kW)	Rated torque (Nm)	Rated speed (rpm)	Shaft height	Article number	Article number	Frame size	
0.40	1.27	3000	SH45	1FL6042 -1AF61-0	□ □ 1	6SL3210-5FE10-4UA0	FSAA
0.75	2.39	3000		1FL6044 -1AF61-0	□ □ 1	6SL3210-5FE10-8UA0	
0.75	3.58	2000		1FL6061 -1AC61-0	□ □ 1	6SL3210-5FE11-0UA0	FSA
1.00	4.78	2000	SH65	1FL6062 -1AC61-0	□ □ 1	6SL3210-5FE11-5UA0	
1.50	7.16	2000		1FL6064 -1AC61-0	□ □ 1	6SL3210-5FE11-5UA0	
1.75	8.36	2000		1FL6066 -1AC61-0	□ □ 1	6SL3210-5FE12-0UA0	FSB
2.00	9.55	2000	SH90	1FL6067 -1AC61-0	□ □ 1	6SL3210-5FE12-0UA0	
2.50	11.90	2000		1FL6090 -1AC61-0	□ □ 1	6SL3210-5FE13-5UA0	
3.50	16.70	2000		1FL6092 -1AC61-0	□ □ 1	6SL3210-5FE13-5UA0	FSC
5.00	23.90	2000	1FL6094 -1AC61-0	□ □ 1	6SL3210-5FE15-0UA0		
7.00	33.40	2000	1FL6096 -1AC61-0	□ □ 1	6SL3210-5FE17-0UA0		
Encoder type		Incremental encoder TTL 2500 S/R		A			
		Absolute encoder 20-bit single-turn + 12-bit multi-turn		L			
Shaft version		Feather key, without holding brake		A			
Feather key and holding brake		Feather key, with holding brake		B			
		Plain shaft, without holding brake		G			
		Plain shaft, with holding brake		H			

Full range of options

Selection and ordering information

MOTION-CONNECT 300 cables and connectors (between SINAMICS V90 servo drive and SIMOTICS S-1FL6 motor)

Name	Article No. 6FX3002-...	No. of cores x cross-section (mm ²)	Length (m)
MOTION-CONNECT MC300 power cable for FSAA and FSA	5CL01-1AD0	4 x 1.5	3
	5CL01-1AF0	4 x 1.5	5
	5CL01-1AH0	4 x 1.5	7
	5CL01-1BA0	4 x 1.5	10
	5CL01-1CA0	4 x 1.5	20
MOTION-CONNECT MC300 power cable for FSB and FSC	5CL11-1AD0	4 x 2.5	3
	5CL11-1AF0	4 x 2.5	5
	5CL11-1AH0	4 x 2.5	7
	5CL11-1BA0	4 x 2.5	10
	5CL11-1CA0	4 x 2.5	20
MOTION-CONNECT MC300 encoder cable (for absolute encoder)	2DB10-1AD0	3 x 2 x 0.22 + 2 x 2 x 0.25	3
	2DB10-1AF0	3 x 2 x 0.22 + 2 x 2 x 0.25	5
	2DB10-1AH0	3 x 2 x 0.22 + 2 x 2 x 0.25	7
	2DB10-1BA0	3 x 2 x 0.22 + 2 x 2 x 0.25	10
	2DB10-1CA0	3 x 2 x 0.22 + 2 x 2 x 0.25	20
MOTION-CONNECT MC300 encoder cable (for incremental en- coder)	2CT10-1AD0	3 x 2 x 0.22 + 2 x 2 x 0.25	3
	2CT10-1AF0	3 x 2 x 0.22 + 2 x 2 x 0.25	5
	2CT10-1AH0	3 x 2 x 0.22 + 2 x 2 x 0.25	7
	2CT10-1BA0	3 x 2 x 0.22 + 2 x 2 x 0.25	10
	2CT10-1CA0	3 x 2 x 0.22 + 2 x 2 x 0.25	20
MOTION-CONNECT MC300 brake cable (for holding brake)	5BL02-1AD0	2 x 0.75	3
	5BL02-1AF0	2 x 0.75	5
	5BL02-1AH0	2 x 0.75	7
	5BL02-1BA0	2 x 0.75	10
	5BL02-1CA0	2 x 0.75	20

Name	Used for	Article No.* 6FX2003-...
Power connector	Motor side	OLL11
Absolute encoder connector	Motor side	ODB11
Incremental encoder connector	Motor side	OSL11
Brake connector	Motor side	OLL51
Encoder connector	Drive side	OSB14

*Connector, packaging unit 30 pieces

Connector and cable (between V90 servo drive and control system)

Name	Article No.
Control/setpoint MDR 50-pin connector (packaging unit: 30 pieces)	6SL3260-2NA00-0VA0
Control/setpoint cable, 1 m cable, with a connector (MDR 50-pin connector, free pins to controller side)	6SL3260-4NA00-1VB0
Control/setpoint cable, 0.5 m cable, with connectors on both sides and a separate terminal block (MDR 50-pin connector, terminal block to controller side)	6SL3260-4NA00-1VA5

Recommended line-side component

V90 Article No.	Line filter ¹		Recommended fuse/circuit breaker Corresponding to the IEC standard		
	Rated current (A)	Article No.	Standard fuse Current (A)	Article No.	Circuit breaker Article No.
6SL3210-5FE...					
10-4UA0	5	6SL3203-0BE15-0VA0	6	3NA3801-6	3RV2021-1DA10
10-8UA0	5		6	3NA3801-6	3RV2021-1EA10
11-0UA0	5		10	3NA3803-6	3RV2021-1FA10
11-5UA0	12	6SL3203-0BE21-2VA0	16	3NA3805-6	3RV2021-1JA10
12-0UA0	12		16	3NA3805-6	3RV2021-4AA10
13-5UA0	20	6SL3203-0BE22-0VA0	25	3NA3807-6	3RV2021-4BA10
15-0UA0	20		25	3NA3807-6	3RV2021-4DA10
17-0UA0	20		25	3NA3810-6	3RV2021-4DA10

External braking resistor²

Frame size	Resistance (Ω)	Max. Power (kW)	Rated power (W)	Max. energy (KJ)
FSAA	533	1.2	30	2.4
FSA	160	4	100	8.0
FSB	70	9.1	229	18
FSC	27	23.7	1185	190

Spare parts

Replacement fan	Article No.
FSB	6SL3200-0WF00-0AA0
FSC	6SL3200-0WF01-0AA0

Accessories

SINAMICS SD card	6SL3054-4AG00-2AA0
Training case SINAMICS V90	6AG1067-3AA00-0AB0

1 With one of the recommended line filter, EN61008-3 category C2 can be reached in combination with SINAMICS V90

2 When the internal braking resistor is not sufficient, select a standard braking resistor according to the table

Find out more:

siemens.com/ids

Experience how Integrated Drive Systems can boost the competitiveness of production plants and entire companies in every sector.

The advantages of Integrated Drive Systems at a glance

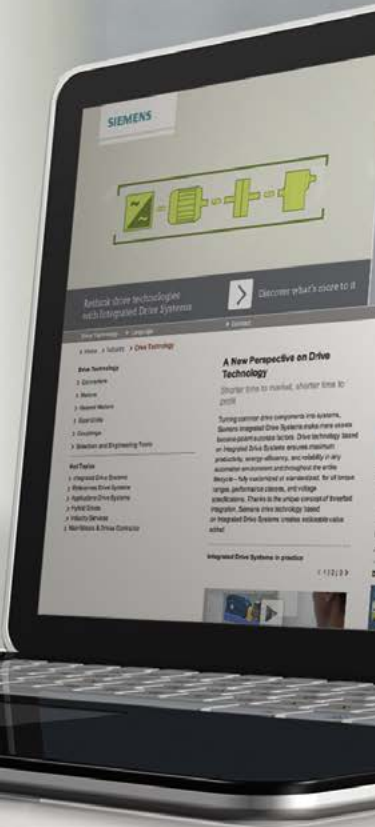

Subject to change without prior notice
Article No.: E20001-A280-P670-V1-7600
DISPO 21500
WÜ/66744 V6.MKSINA.WES WS 04157.0
Printed in Germany
© Siemens AG 2015

The information provided in this brochure contains merely general descriptions or characteristics of performance which in case of actual use do not always apply as described or which may change as a result of further development of the products. An obligation to provide the respective characteristics shall only exist if expressly agreed in the terms of contract.

All product designations may be trademarks or product names of Siemens AG or supplier companies whose use by third parties for their own purposes could violate the rights of the owners

Siemens provides products and solutions with industrial security functions that support the secure operation of plants, solutions, machines, equipment and/or networks. They are important components in a holistic industrial security concept. With this in mind, Siemens' products and solutions undergo continuous development. Siemens recommends strongly that you regularly check for product updates.

For the secure operation of Siemens products and solutions, it is necessary to take suitable preventive action (e.g. cell protection concept) and integrate each component into a holistic, state-of-the-art industrial security concept. Third-party products that may be in use should also be considered. For more information about industrial security, visit <http://www.siemens.com/industrialsecurity>.

To stay informed about product updates as they occur, sign up for a product-specific newsletter. For more information, visit <http://support.automation.siemens.com>

Follow us on:
twitter.com/siemensindustry
youtube.com/siemens

Siemens AG
Digital Factory
P.O. Box 31 80
91050 Erlangen
GERMANY